

INSTRUCTION & MAINTENANCE MANUAL

Techtrol Magnetic, Liquid Level Gauge - MLG



Innovating Level Controls since 1984

Introduction :

This is simple, accurate, maintenance-free and reliable float operated technique adopted for tank level gauging in storage as well as in pressurized tanks.

Construction & Operation :

It consists of a chamber and an internal float in nonmagnetic material, compatible with the liquid. The float containing a magnetic system rides on liquid level and is coupled to an external visual indication, which comes in two designs,

a) Magnetic Follower Capsule b) Bicolour Rotating Flappers.

a) Magnetic Follower Capsule : (Fig.-1a) It consists of a RED magnetic follower capsule, that moves within a transparent glass tube filled with water (to reduce friction) and can be read against a scale. The level is indicated by the annular White ring of the follower capsule.

b) Bicolour Rotating Flappers : (Fig.-1b) It consists of a series of bicolour flappers, WHITE on front side and a contrasting RED colour on the reverse. These flappers flip over corresponding to float movement, thus changing their colour from WHITE to RED as the float rises and changing back to white, when float falls. As such, liquid level is represented by an external RED column.

The "External Visual Indication" is placed parallel to the chamber in case of 'Side Mounting' (Fig.-1) and on the top of the chamber for 'Top Mounting' (Fig.-1). The construction of the gauge is modified for Top Mounting. A dipstick type float (with stem) is caged within a still well and moves as per changes in liquid level. Its upper end carries a magnetic system to actuate the external visual indication.



Accessories :

Mono or Bistable Switch : Adjustable, with external mounting can be provided for level control.

'X' Mitter : With external mounting can be provided with 4-20 mA out put.

Fig.-1

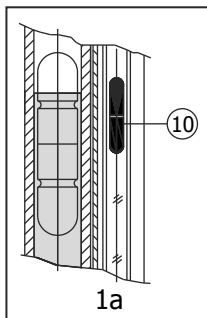

1a
Magnetic Follower Capsule

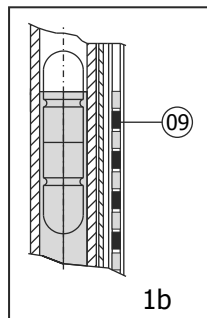

1b
Bicolour Rotating Flappers

- | | |
|---|-----------------------------|
| 01) Liquid Chamber | 11) Calibrated Scale |
| 02) Float | 12) Nuts, Bolts & Washers |
| 03) Process Flange | 13) Gasket |
| 04) Chamber Flange | 14) Float Retainer (Spring) |
| 05) Vent Plug | 15) Switch (adjustable) |
| 06) Drain Plug | 16) 'X' Mitter |
| 07) Local Indicator Housing | 17) Perforated still well |
| 08) Indicator mtg. Clamps | 18) Magnet Chamber |
| 09) Local Indicator (Flapper type) | 19) Stem |
| 10) Local Indicator (Follower Capsule type) | 20) Still well flange |

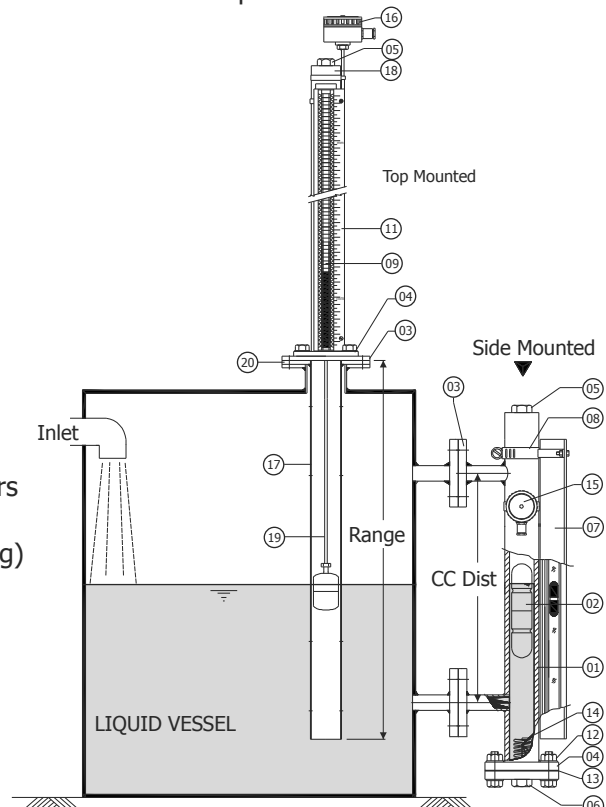

Non-valid Guarantee Claims : Abnormal usage, mishandling, breakage, disaster, incorrect installation and usage beyond limits of specified operating conditions / electrical parameters.

Installation :

Side or Top Mounting (Refer Fig.-1 to get a general idea of Level Gauge)

1) SIDE MOUNTING :

- Select a suitable location on tank, where vibrations if any are minimum.
- Ensure that process connections and C=C distance of level gauge match with those on tank.
- Ensure counter connections provided on tank are vertical and in plumb line.
- Provided separate Isolating valve on the tank for Safety and removal of Level Gauge for repairs / Maintenance.
- Minimum clearance required from bottom nozzle to ground for Float removal / replacement = 500 mm.

2) TOP MOUNTING :

- Ensure that ID of mounting nozzle is greater than float diameter and still well diameter (dw).
- Still well is recommended to be used, where 1) Turbulence is present. 2) Ranges beyond 1.5 mtrs.
- Provide suitable gasket between the flanges and appropriate thread sealant between threads before bolting / tightening, to ensure zero leakage through joints.
- In case of Magnetic follower capsule glass tube should be filled with clean water & the capsule is submerged in water.
- Ensure that the Follower capsule or Flappers are properly coupled with magnetic float to get level indication. If required, coupling of float and follower capsule can be made using external magnet.
- Ensure intact coupling between float & follower capsule / flappers after opening of Isolation valve, if not open isolation valve gradually.
- Adjust Scale, so that zero marking on it corresponds to dead liquid level in gauge. (Float starting point)

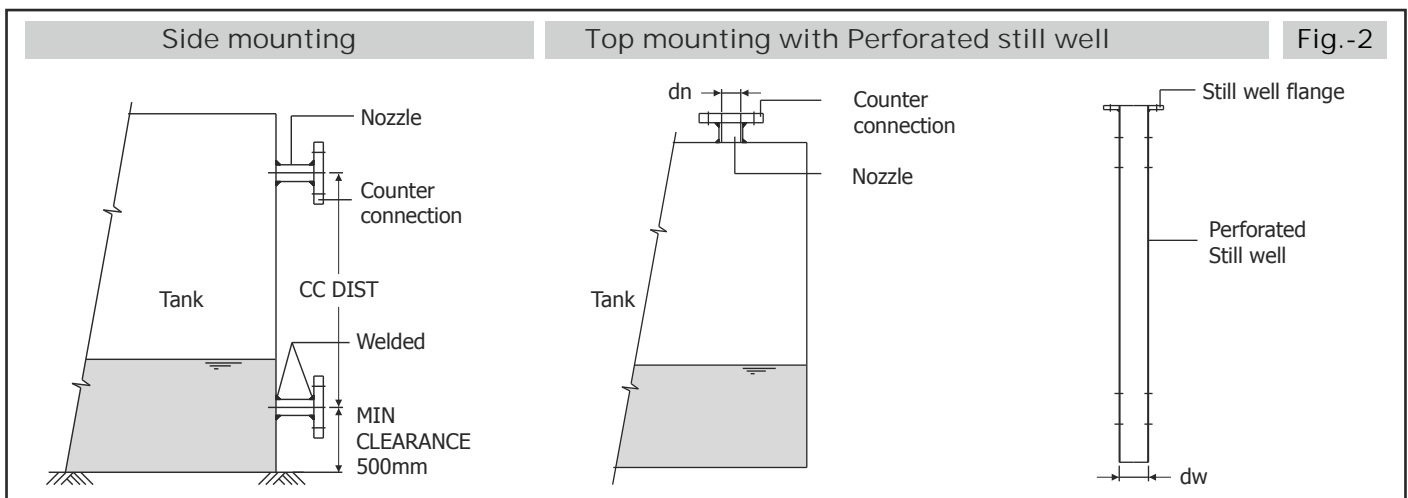

External Mounting of Switch on Gauge : (Fig.-3)

- Before actually turning ON the power make sure all the wiring is done correctly.
- Fix the position of switch at desired location on liquid chamber, by adjusting position of hose clamp. Ensure Cable gland position is towards downward.
- Ensure switch enclosure position is adjacent to liquid chamber.
- By using switch (reed type) to control resistive load a control unit should be used.

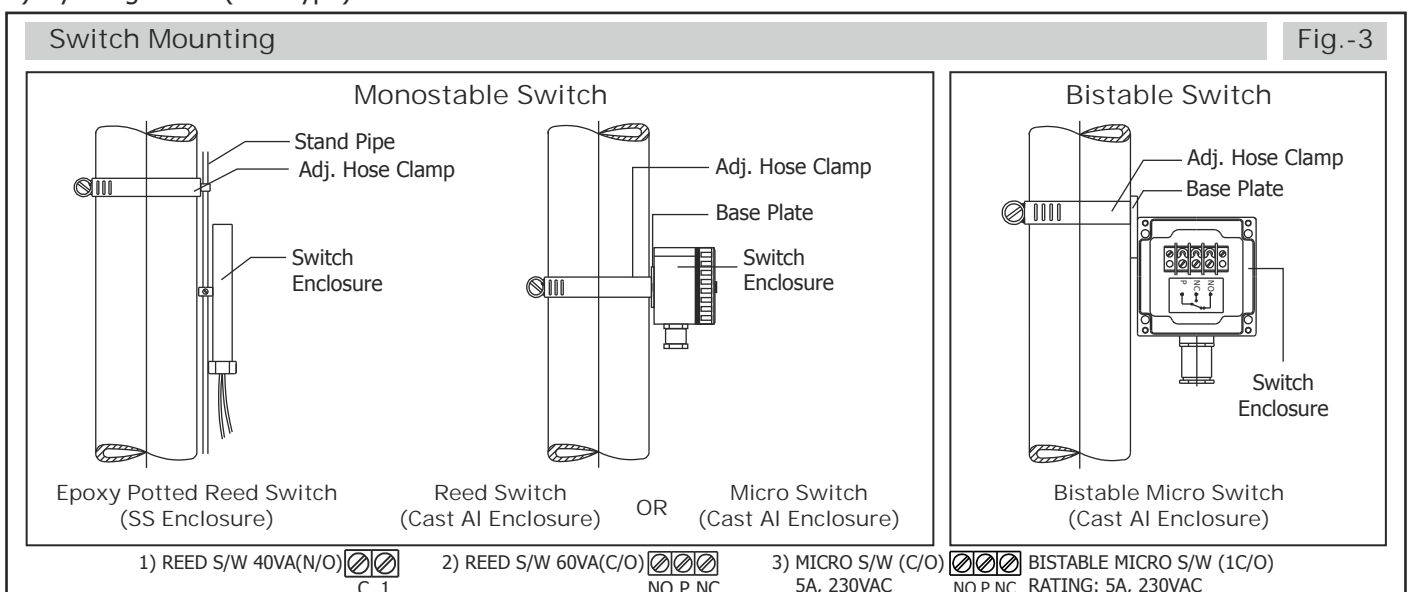

CAUTION : Usage of instruments beyond the limits of specified Pressure, Temperature, Voltage & Current, may cause permanent damage beyond repair.

Installation of Transmitter : (Fig.-4)

- Before actually turning ON the power make sure all wiring is done correctly.
- Ensure transducer protection tube is adjacent to liquid chamber.

'X' MITTER INSTALLATION

Fig.-4

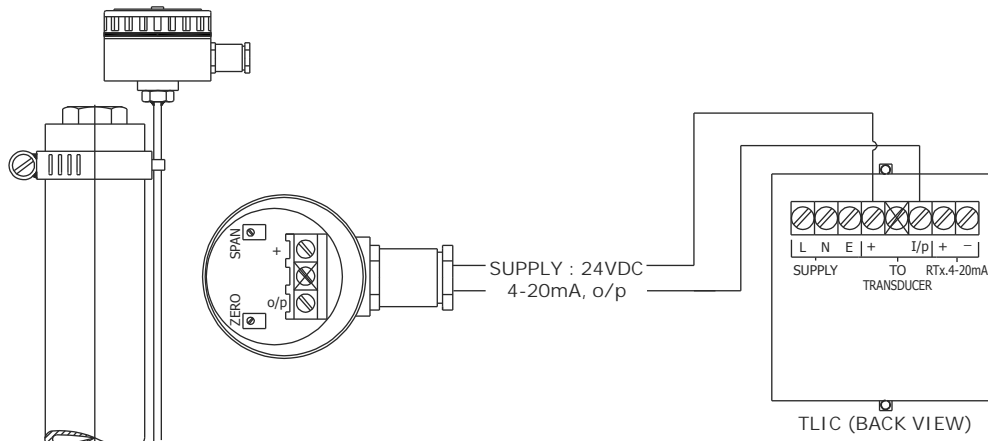

Maintenance :

In case of liquids with dirt or suspended particles, periodic cleaning of float and chamber is essential.

Change of Float (Side Mounting Type) :

Remove bottom flange carefully to avoid the float damage. Clean the float and chamber properly and refit the float with arrow mark on the float pointing upwards.

Change of Float (Top Mounting Type) :

Whereas in case of top mounting version, float can be cleaned by removing the instruments from top of the tank, ensure that stem does not get damaged during cleaning process.

In case of gauge having follower capsule indication ensure that indicating glass tube has proper visibility, if required it may be cleaned and refilled with water. Also confirm that water level in indicating tube is maintained.

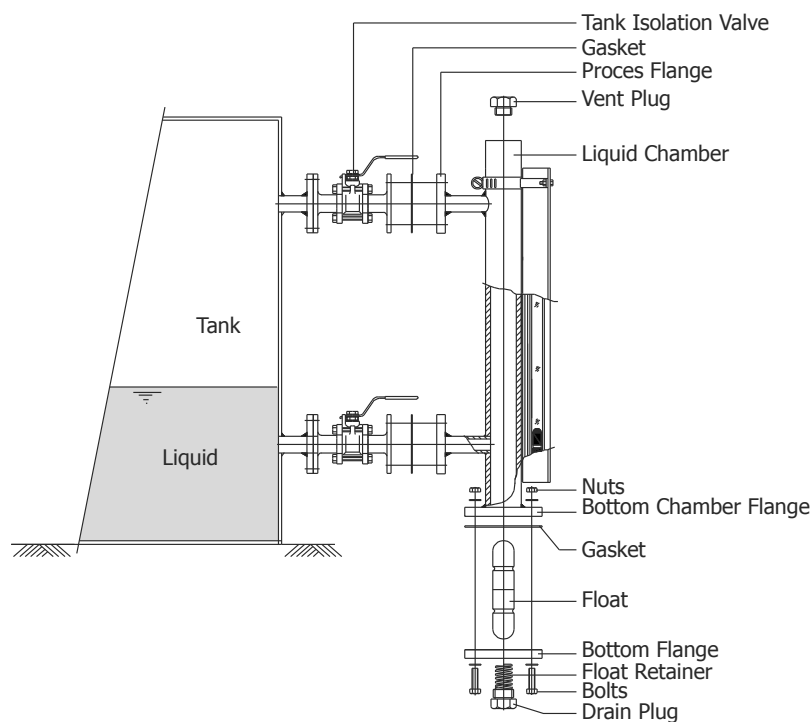

Precautions :

Float is designed for specific service on the basis of liquid density & corrosivity. Hence ensure that density of service liquid is in line with that specified while ordering. Besides in case you want to use the gauge for other service, consult factory or ensure that liquid density matches float density and liquid will not corrode its MOC.

Non-valid Guarantee Claims : Abnormal usage, mishandling, breakage, disaster, incorrect installation and usage beyond limits of specified operating conditions / electrical parameters.

Trouble Shooting

Problem	Cause	Solution
No movement of magnetic Follower capsule, inspite of change in liquid level.	a. Glass tube is not filled with water. b. Disengagement of magnetic coupling between float and capsule	Fill glass tube with water Lift the capsule unto float with aid of external magnet.
No change in gauge indication inspite of change in liquid level.	a. Float may be damaged / punctured. b. Liquid density is lesser than that specified in order.	Replace float. Replace float to match Density
Visual level indication is not matching with actual liquid level.	a. Scale may have shifted. b. Nominal difference in actual and specified liquid density.	Align scale properly. Align scale properly.
Visual level indication changes in steps, in spite of gradual change.	Gauge is not in plumb line.	Align the mounting.
Switch is not operating.	a. Wiring connection is loose. b. Wire connection not proper. c. Switch mounting not proper. d. Switch burnt due to load more than its rating.	Tighten connection. Wire properly as specified. Reposition the switch correctly. Change switch.
No transmitter out put.	Wiring connection not proper.	Wire properly.
Transmitter operation is erratic.	a. Ensure transmitter guide tube is fitted properly with liquid chamber b. Reed switch/switches may be damaged.	Tighten guide tube properly. Contact factory.

Construction Types

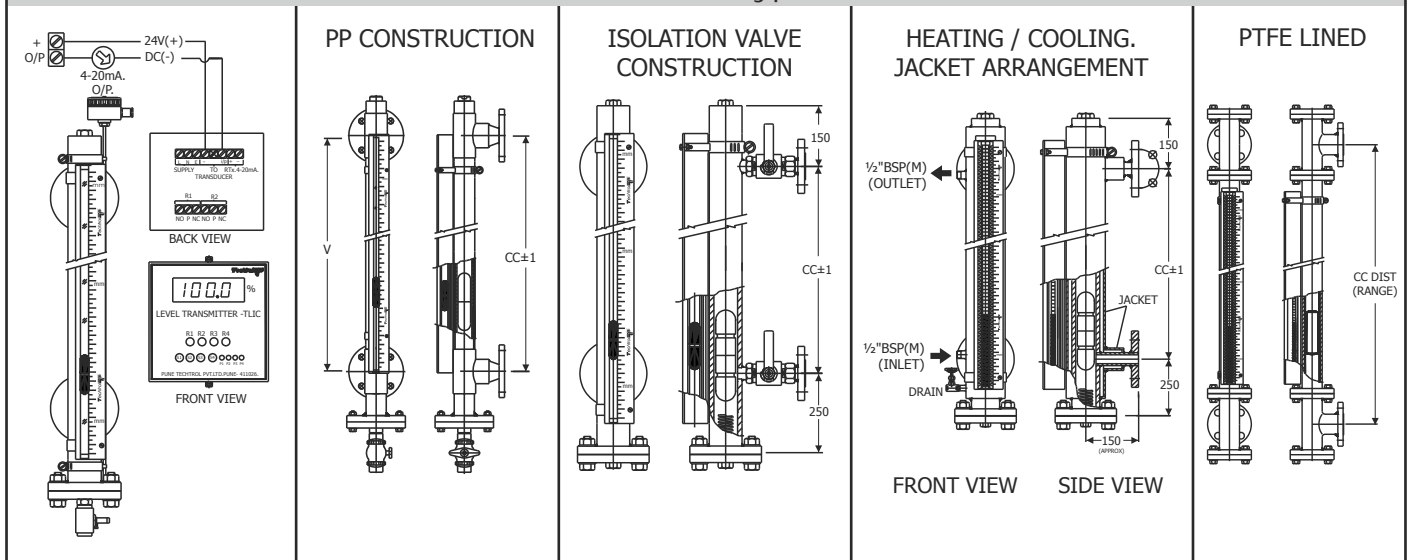

CAUTION : Usage of instruments beyond the limits of specified Pressure, Temperature, Voltage & Current, may cause permanent damage beyond repair.

PUNE TECHTROL PVT LTD

S-18, MIDC, Bhosari, Pune : 411026 India

+91-20-66342900, 27121052

66342998

ho@punetechtrol.com

www.punetechtrol.com



R A T E D

NSIC-CRISIL SE-1A